



深圳市明途光电科技有限公司

SHENZHEN MINGTOLIGHT TECHNOLOGY CO., LTD.

# 产品规格书

## SPECIFICATION

顾客名称 Custome		产品类型 Product Type	TOP LED
顾客型号 Customer Type		产品型号 Type	MT-F3528QRQBC-CFNGRE1
版本号 Version NO	2016 版	产品名称 Product	3528红/蓝双色反极



地址：广东省深圳市龙岗区横岗街道坳二路 30 号 A 栋 4 楼

Add: Longgang district of shenzhen city, guangdong province, col 2 30

A cross bar street building 4th floor

电话 (TEL):86-0755-29768009, 29610190, 27802773

传真 (FAX):086-0755-29028130

邮编 ( ZIP):518115

<http://www.mtolight.com>

研发中心 Research & Development Center			客户 (加盖公章) Customer (Stamp)
批准 APPROVE	审核 CHECK	制定 DRAW	确认 CONFIRM



--	--	--	--

## MT-F3528QRQBC-CFNGRE1

片式发光二极管  
TOP Light Emitting Diode

### 技术数据表 Technical Data Sheet

本产品主要作为信号指示及照明的电子元件广泛应用于各类使用表面贴装结构的电子产品中，如家用电器的开关指示灯、手机键盘灯、汽车仪表盘照明，本产品也广泛用于各类室内外的装饰照明

This product is generally used as indicator and luminary for electronic equipment such as household appliance, communication equipment, and dashboard, And it also be widely used for indoor and outdoor decorative lighting.

<p><b>特性:</b> <b>Features:</b></p>	<ul style="list-style-type: none"> <li>● 管芯材料: InGaN Material: InGaN</li> <li>● 封装材料: 硅胶 Encapsulation: The silicone</li> <li>● 焊接方法: 无铅回流焊 Soldering methods: Pb-Free reflow soldering</li> <li>● 光强度高, 功耗低, 可靠性好, 寿命长 High Luminous Intensity, Low Power Dissipation, good Reliability and Long Life</li> <li>● 符合欧盟公布的 ROHS 指令要求 Complied With ROHS Directive</li> </ul>	<p>发光颜色: 红/蓝色 Emitting Color: Red/Blue</p>
--	---	--

目录  
Catalogue

外型尺寸 Outline Dimensions.....	2
电性参数 Electrical Characteristics.....	3
典型特性曲线 Typical Characteristic Curves.....	4
可靠性实验 Reliability Test Items And Conditions.....	5
包装 Packaging.....	6
焊接指导	

Guideline for Soldering..... 8  
 使用注意事项  
 Precautions..... 10

\*产品规格如因工艺改进而有所改变，恕不另行通知。  
 \*The Specifications of the product may be modified for improvement without notice.

## 外形尺寸

## Outline Dimension

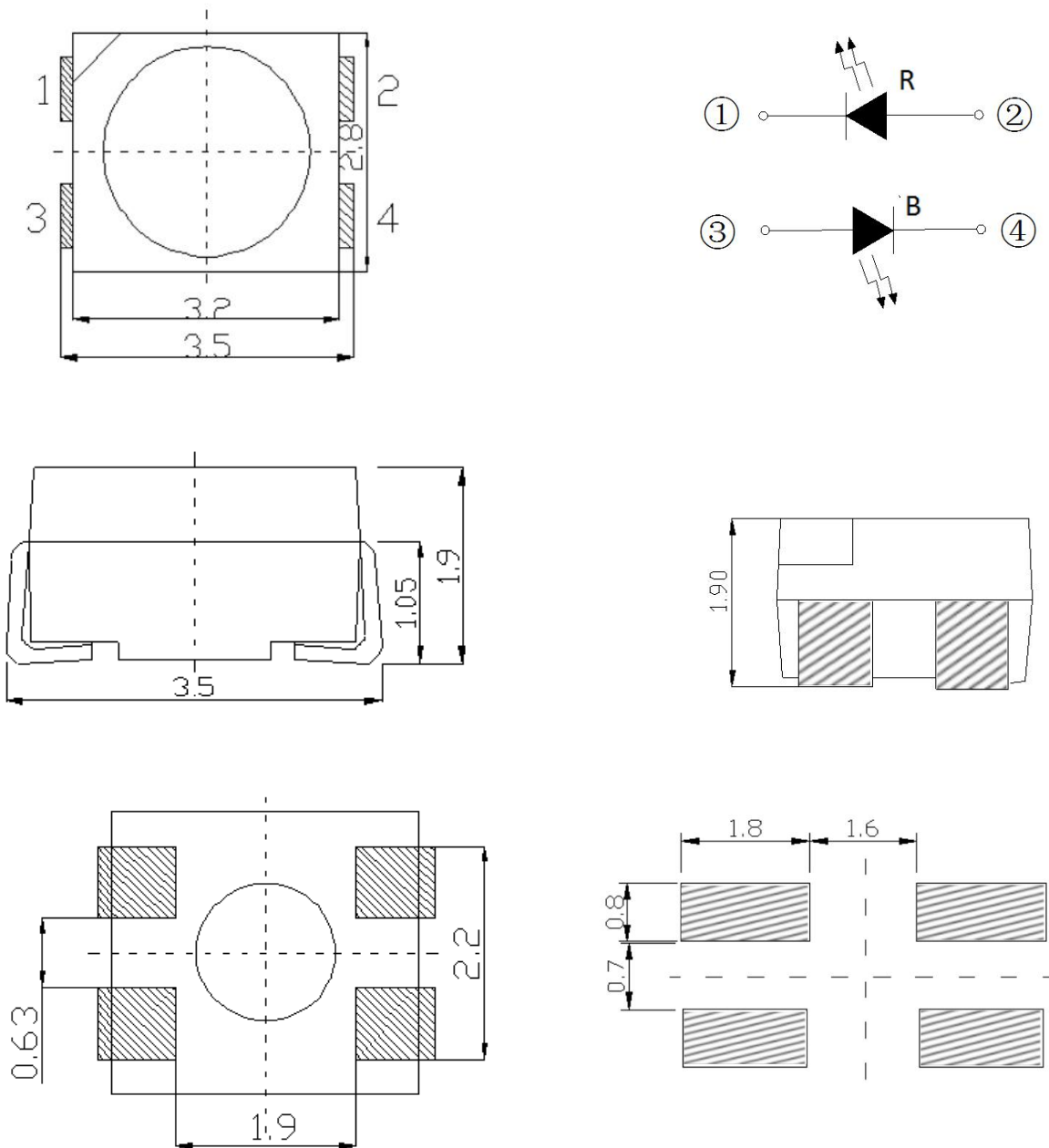

推荐焊盘尺寸  
 Recommended Soldering Pad

### 电性参数

### Electrical Characteristics

#### 1、极限参数（温度=25℃）：

Absolute Maximum Ratings(Temperature=25℃)：

参数名称 Parameter	符号 Symbol	数值 Rating		单位 Unit
正向电流 Forward Current	<b>IF</b>	R/B	25	mA
正向脉冲电流* Pulse Forward Current*	<b>IFP</b>	R	75	mA
		B	100	
功耗 Power Dissipation	<b>Pd</b>	R	65	mW
		B	90	
反向电压 Reverse Voltage	<b>VR</b>	R/B	5	V
工作温度 Operating Temperature	<b>Topr</b>	-30℃ ~ + 85℃		℃
贮存温度 Storage Temperature	<b>Tstg</b>	-40℃ ~ + 90℃		℃

\*注：脉冲宽度≤0.1ms，占空比≤1/10

\* Note: Pulse width≤0.1ms, Duty≤1/10

#### 2、光电参数（温度=25℃）：

Electro-Optical Characteristics (Temperature=25°C) :

## 典型特性曲线

## Typical Characteristics Curves

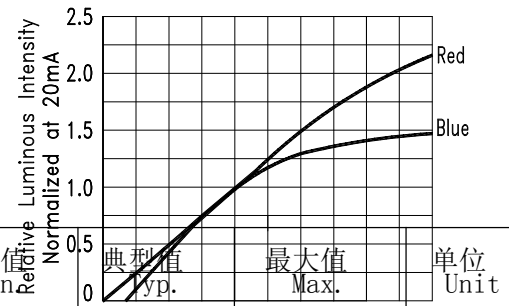
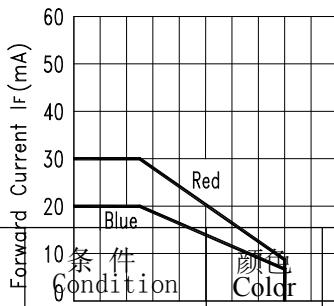
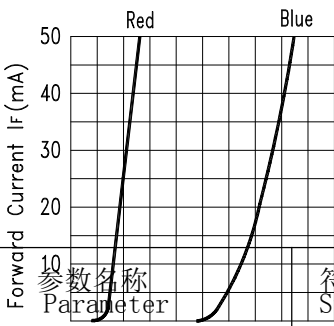
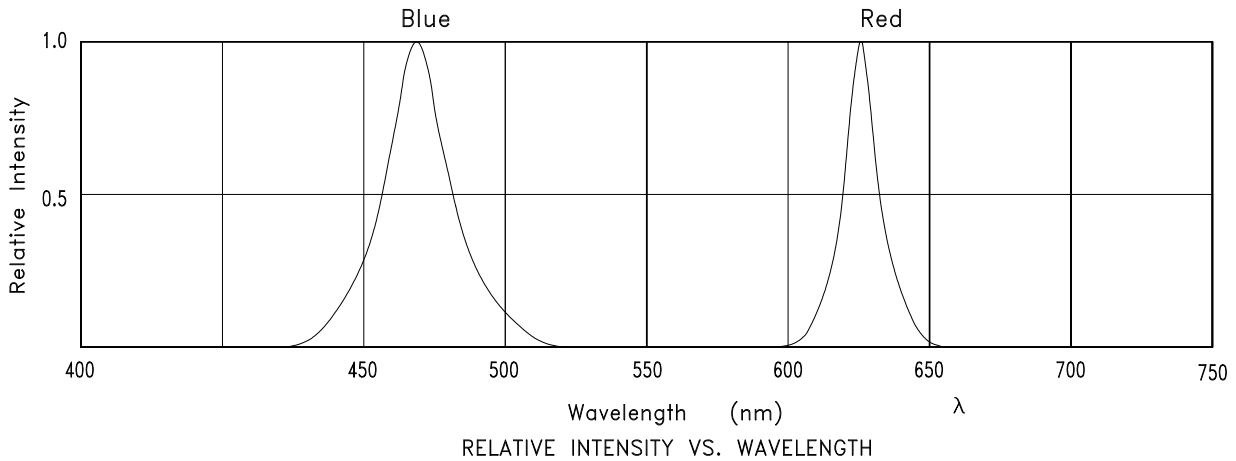

参数名称 Parameter	符号 Symbol	条件 Condition	颜色 Color	最小值 Min	典型值 Typ.	最大值 Max.	单位 Unit
正向电压 Forward Voltage $V_F$	(V)	IF=20mA	R/B	1.8	2.0	2.8	V
光强 Luminous Intensity	IV	IF=20mA	R/B	---	300	---	mcd
主波长 Dominant Wavelength	$\lambda_d$	IF=20mA	R/B	---	465	---	nm
峰值波长 Peak Wavelength	$\lambda_p$	IF=20mA	R/B	---	470	---	nm
光谱辐射半波宽度 Spectrum Radiation Bandwidth	$\Delta\lambda$	IF=20mA	R/B	---	20	---	nm
反向电流 Reverse Current $I_R$	( $\mu A$ )	TA=25°C, VR=5V	R/B	---	---	5	uA
视角 View Angle	20/1/2	IF=20mA	R/B	---	120	---	deg

### 可靠性试验

#### Reliability Test Items And Conditions

实验项目 Test Items	参考标准 Reference	实验条件 Test Conditions	时间 Time	样品数 Quantity	判据 Criterion
冷热冲击 Thermal Shock	MIL-STD-202G	-40 °C (30min) ~ +100°C (30min)	循环 100 次 100 cycles	22	0/22
湿热循环 Temperature And Humidity Cyclic	JEITA ED-4701 200 203	-10 °C ~ +65°C, 0% ~90%, 24 hrs. /1cycle	循环 10 次 10 cycles	22	0/22
高温储存 High Temperature Storage	JEITA ED-4701 200 201	Ta=100°C	1000 hrs	22	0/22
低温储存 Low Temperature Storage	JEITA ED-4701 200 202	Ta=-40°C	1000 hrs	22	0/22
高温高湿储存 High Temperature High Humidity Storage	JEITA ED-4701 100 103	Ta=80°C RH=90%	1000 hrs	22	0/22
高温寿命 High Temperature Life Test	JESD22-A108D	Ta=80°C IF=20mA	1000 hrs	22	0/22

常温寿命试验 Life Test	JESD22-A108D	Ta=25°C IF=20mA	1000 hrs	22	0/22
耐焊接热 Resistance to Soldering Heat	JEITA ED-4701 300 301	红外回流焊法 Reflow Soldering	循环 3 次 3 times	22	0/22

### 失效判断标准 Criteria For Judging Damage

测试项目 Items	符号 Symbol	实验条件 Test Conditions	失效判断标准 II Criteria For Judging Damage II
正向电压 Forward Voltage	VF	IF=5mA	≧USL
反向电流 Reverse Current	IR	VR=5V	≧USL
光强 Luminous Intensity	IV	IF=5MA	≧LSL
耐焊接热 Resistance to Soldering Heat			材料无内部裂痕、无材料间爆裂、剥离、无死灯 Material without internal cracks, no material between stripped, no deaded light.

USL:标准值上限值, LSL:标准值上限值。USL:Upper Standard Level, LSL:Lower Standard Level

### 包装 (1)

### Packaging(1)

### 载带 Carrier Tape

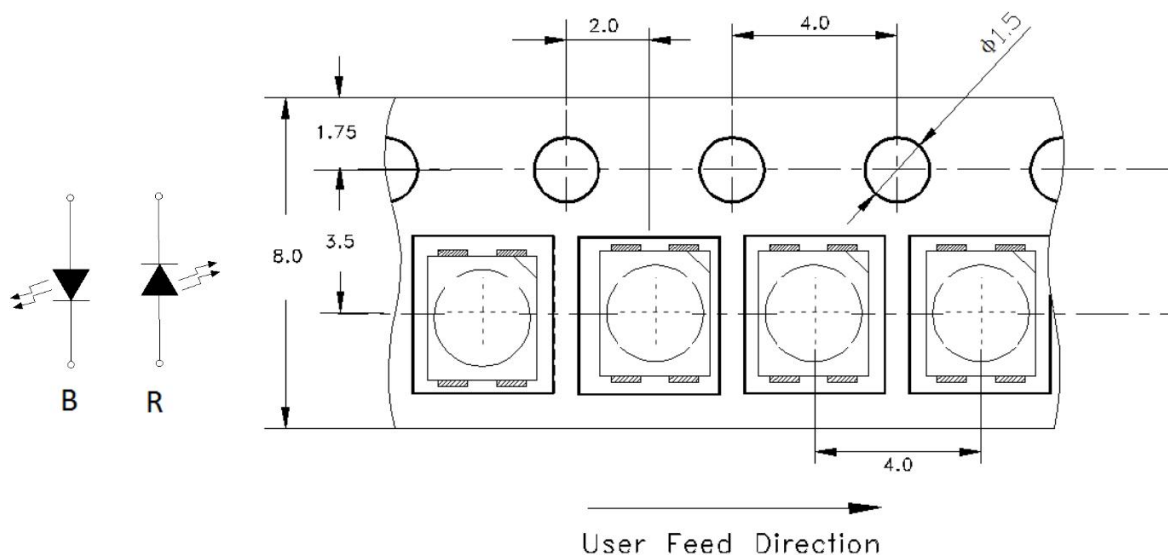

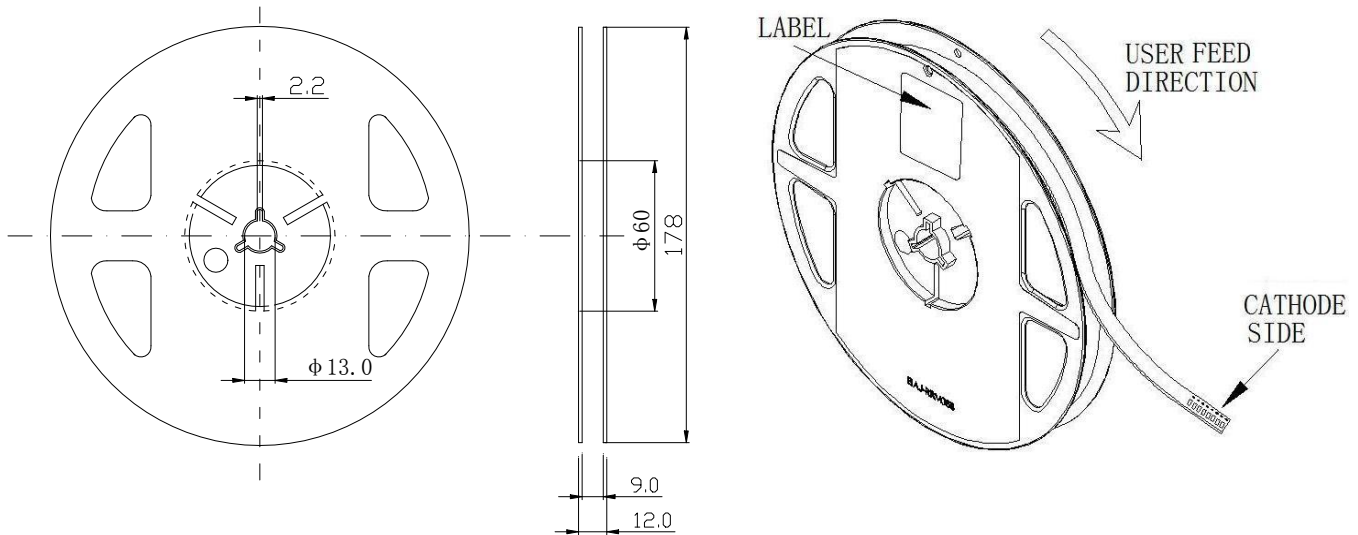

包装 (2)

Packaging(2)

## 防潮抗静电包装 Moisture Proof and Anti-Electrostatic Foil Bag

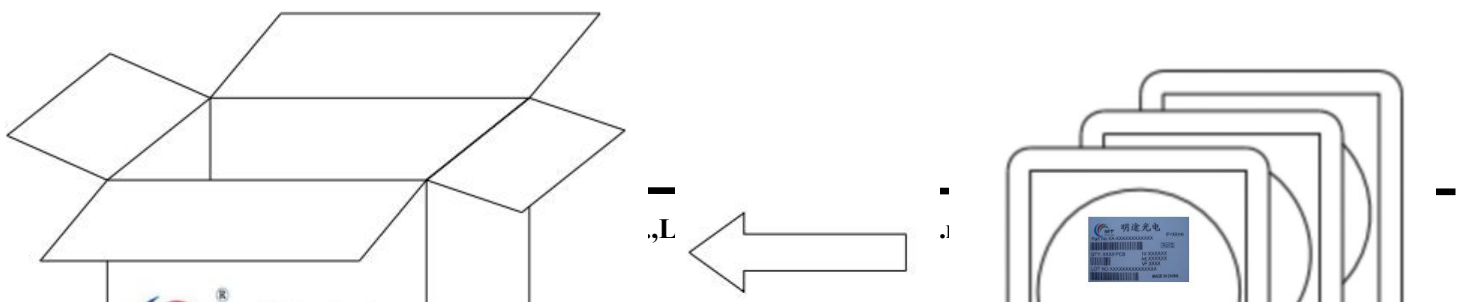
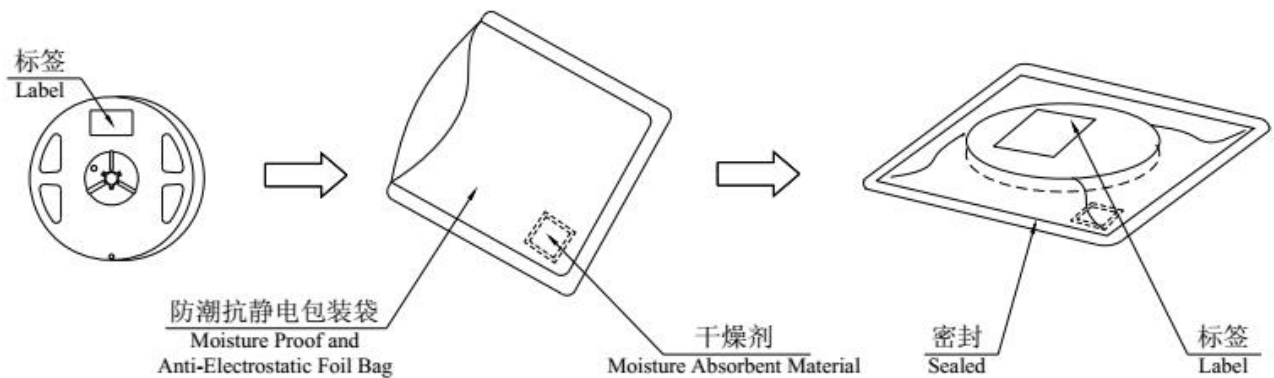



## 标签说明 Label Explanation

Part No: 产品型号

QTY: 数量 Quantity

LOT NO: 批号 Lot Number

IV: 光强范围 Wavelength Range

$\lambda$  d: 波长范围 Luminous Intensity Range

VF: 正向电压范围 Forward Voltage Range

IF: 以上数据测试电流 Testing Current



## 焊接指导 (1)

### Guideline for Soldering(1)

#### 1、使用烙铁人手焊接

##### Hand Soldering

推荐使用功率低于 20W 的烙铁，焊接时烙铁的温度必须保持在 360°C 以下，且每个电极只能进行一次焊接，每次焊接的持续时间不得超过 3 秒。

人手焊接过程中的不慎操作易引起 LED 产品的损坏，应当小心谨慎。

A soldering iron of less than 20W is recommended to be used in Hand Soldering. Please keep the temperature of the soldering iron under 360°C while soldering. Each terminal of the LED is to go for less than 3 second and for one time only.

Be careful because the damage of the product is often started at the time of the hand soldering.

#### 2、回流焊接：推荐使用以下无铅回流焊温度图进行。

Reflow Soldering: Use the conditions shown in the under Figure of Pb-Free Reflow Soldering.

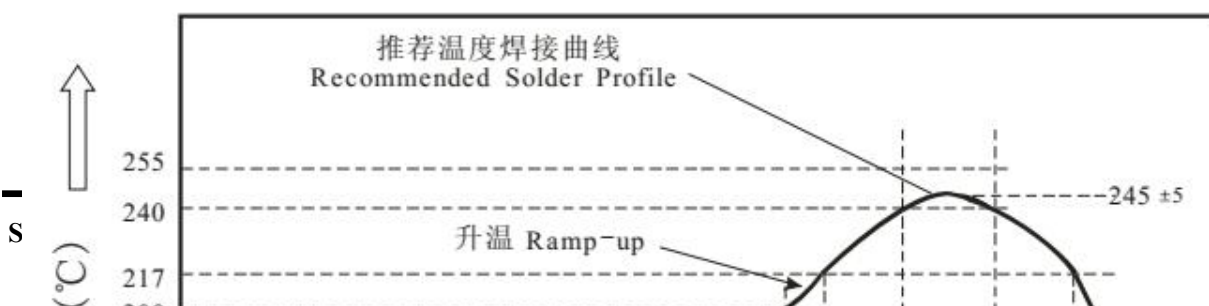

- 回流焊接最多只能进行两次。  
Reflow soldering should not be done more than two times.
- 在回流焊接升温过程中，请不要对 LED 施加任何压力。  
Stress on the LEDs should be avoided during heating in soldering process.
- 在焊接完成后，待产品温度下降到室温之后，再进行其他处理。  
After soldering, do not deal with the product before its temperature drop down to room temperature.

### 焊接指导 (2)

#### Guideline for Soldering

---

### 3. 清洗:

#### Cleaning

在焊接后推荐使用酒精进行清洗，在温度不高于 30°C 的条件下持续 3 分钟，不高于 50°C 的条件下持续 30 秒。使用其他类似溶剂清洗前，请先确定使用的溶剂不会对 LED 的封装和环氧树脂部分造成损伤。

超声波清洗也是有效的方法，一般最大功率不应超过 300W，否则可能对 LED 造成损伤。请根据具体的情况预先测试清洗条件是否会对 LED 造成损伤。

It is recommended that alcohol be used as a solvent for cleaning after soldering. Cleaning is to go under 30°C for 3, minutes or 50°C for 30 seconds. When using other solvents, it should be confirmed beforehand whether the solvents will dissolve the package and the resin or not.

Ultrasonic cleaning is also an effective way for cleaning. But the influence of Ultrasonic

cleaning on LED depends on factors such as ultrasonic power. Generally, the ultrasonic power should not be higher than 300W. Before cleaning, a pre-test should be done to confirm whether any damage to LED s will occur.

\* 注意:此一般指导原则并不适用于所有 PCB 设计和焊接设备的配置。具体工艺受到诸多因素的影响, 请根据特定的 PCB 设计和焊接设备来确定焊接方案。

\* Note:This general guideline may not apply to all PCB designs and configurations of all soldering equipment. The technique in practice in practice is influenced by many factors, it should be specialized base on the PCB designs and configurations of the soldering equipment..

## 使用注意事项 (1)

### Precautions(1)

#### 1. 贮存：

##### Storage

本产品使用密封防潮坑静电袋包装，并附有干燥剂，未开封的产品有一年的保存时间。

Moisture proof and anti-electrostatic package with moisture absorbent absorbent material is used ,to keep moisture yo a minimum.

开封前，产品须存放在温度不高于 30℃，湿度不高于 60%RH 的环境中。

Before opening the package, the product should be kept at 30℃ or less and humidity less than 60% RH , and be used within a year.

开封后，产品须存放在温度不高于 30℃，湿度不高于 10%RH 的环境中，且应该在 168 小时（7 天）内使用完。建议工作环境为温度不高于 30℃，湿度不高于 60%RH 。



After opening the package, the product should be stored at 30°C or less and humidity less than 10% RH, and be soldered within 168 hours (7 days). It is recommended that the product be operated at the workshop condition of 30°C or less and humidity less than 60%RH.

对于尚未焊接的 LED，如果吸湿剂或包装失效，或者产品没有符合以上有效存储条件，烘焙可以起到一定的性能恢复效果。烘焙条件：(60±5) °C，持续 24 小时。

If the moisture absorbent material has fade away or the LED s have exceeded the storage time, treatment should be performed based on the following condition: (60±5) °C for 24 hours.

### 使用注意事项 (2)

#### Precautions(1)

## 2、设计建议:

### Design Consideration

设计电路时，通过 LED 的电流不能超过规定的最大值，同时，还需要使用保护电阻，否则，微小的电压变化将会引起较大的电流变化，可能导致产品损毁。

建议使用以下 (A) 电路，该电路能够很好的调节通过每个 LED 的电流：不推荐使用 (B) 电路，该电路在持续的电压驱动下，LED 的正向电压 (VF) 发生变化，电流会随之而发生变化，可能使某些 LED 承受不高于规定的电流值。

In designing a circuit, the current through each LED must not exceed the absolute maximum rating specified for each LED. In the meanwhile resistors for protection should be applied, otherwise slight voltage shift will cause big current change, burn out may happen.

It is recommended to use Circuit A which regulates the current flowing through each LED rather than Circuit B. When driving LED s with a constant voltage in Circuit B, the current through the LED s may vary due to the variation in Forward Voltage (VF) of the LED s In the worst case, some LED may be subjected to stresses in excess of the Absolute Maximum Rating.

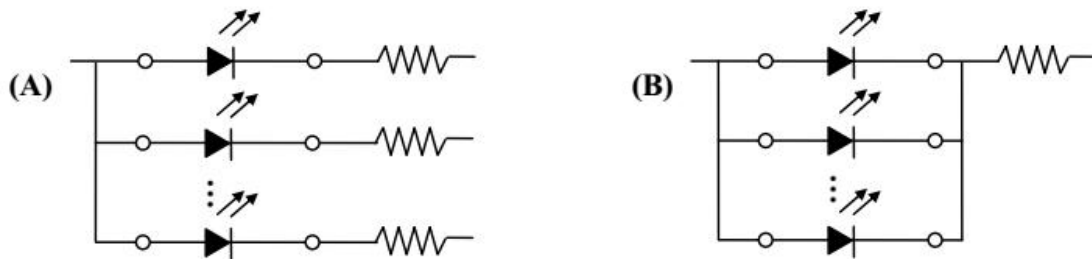

LED 的特性容易因为自身的发热和环境的温度的改变而发生改变。温度的升高会降低 LED 的发光效率、影响发光颜色等，所以在设计时应充分考虑散热的问题。

Thermal Design is paramount importance because heat generation may result may result in the Characteristics decline, such as brightness decreased, Color changed and so on. Please consider the heat generation of the LED s when making the system design.

### 使用注意事项 (3)

#### Precautions(3)

### 3. 其他事项：

#### Others

直接用手拿取产品不但会污染封装树脂表面，也可能由于静电等因素导致产品性能改变。过度的压力也可能直接影响封装内部的管芯和金线，因此请勿对产品施加过度压力，特别当产品处于高温状态下，例如在回流焊接过程中。

When handling the product, touching the encapsulant will not only contaminate its surface, but also affect on its optical. Excessive force to the encapsulant might result in catastrophic failure of the LED s due to die breakage or wire deformation. For this reason, please do not put excessive stress on LED s, especially when the LED s are heated such as during Reflow Soldering.





LED 的环氧树脂封装部分相当脆弱，请勿用坚硬、尖锐的物体刮、擦封装树脂部分。在用镊子夹取的时候也应当小心注意。

The epoxy resin of encapsulant is fragile, so please avoid scratch or friction over the epoxy resin surface. While handling the product with tweezers, do not hold by the epoxy resin, be careful.

#### 4. 眼睛保护忠告：

##### Safety Advice For Human Eyes

LED 发光时，请勿直视发光光源，特别是对于一些光强较高的 LED, 强光可能伤害你的眼睛。

Viewing direct to the light emitting center of the LED s, especially those of great Luminous Intensity will cause great hazard to human eyes. Please be careful.